

# QUANTUM II

SIT-STAND DESK SERIES

## Electric Sit-Stand Desk With Accessories



---

888-993-3757



[www.skutchi.com](http://www.skutchi.com)



## Electric Sit-Stand L-Shape Desk- Triple Motor

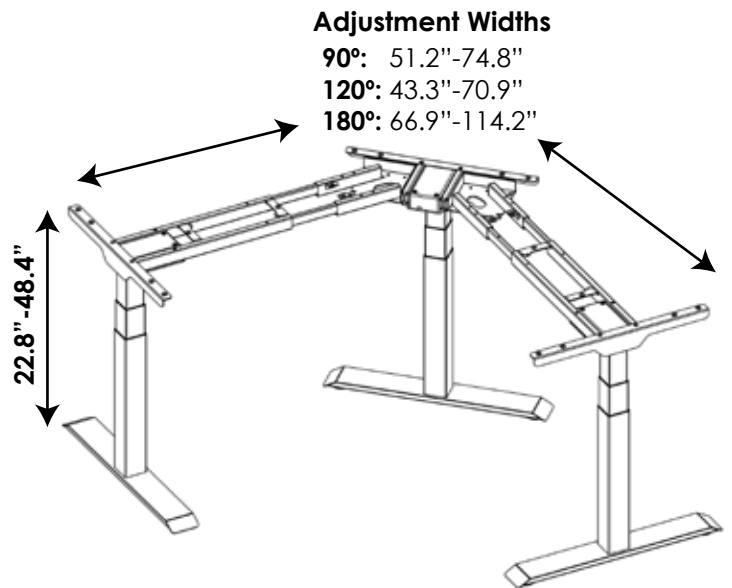

### Adjustment Widths

90°: 51.2"-74.8"

120°: 43.3"-70.9"

180°: 66.9"-114.2"

## Specifications

<b>Product Category:</b>	Electric Sit-Stand Desk
<b>Rank:</b>	Premium
<b>Material:</b>	Plastic, Steel
<b>Dimensions:</b>	22.8"~48.4"x43.3"~114.2"
<b>Frame Orientation:</b>	L-Shape(90°), V(120°), Straight(180°)
<b>Tabletop Thickness:</b>	≥0.98"
<b>Suggest Tabletop Size:</b>	(47.2"~78.7") 3.5" (47.2"~78.7")
<b>Weight Capacity:</b>	330lbs
<b>Width Range:</b>	39.4"~66.9", 46.3"~96"
<b>Height Range:</b>	22.8"~48.4"
<b>Column Design:</b>	Upright Column
<b>Column Segments:</b>	Three Stage Column
<b>Column Size:</b>	2.4" x 2.4", 2.5" x 2.5", 2.8" x 2.8"

<b>Leg Quantity:</b>	3
<b>Frame Color:</b>	Grey
<b>Adjustable Feet Pad:</b>	Yes
<b>Motor Quantity:</b>	3
<b>Power Input:</b>	110V/230V
<b>Power Cord Length:</b>	9.8ft
<b>Max. Speed:</b>	38mm/s
<b>Controller Type:</b>	Button Control Panel
<b>Time Reminder:</b>	Yes
<b>Suggested Operating Temperature:</b>	23°F-104°F
<b>IP Grade:</b>	IP20
<b>Accessory Kit Package:</b>	Normal/Ziplock Polybag

## Dual Motor Electric Sit-Stand Desk With Square Column (Reversed)

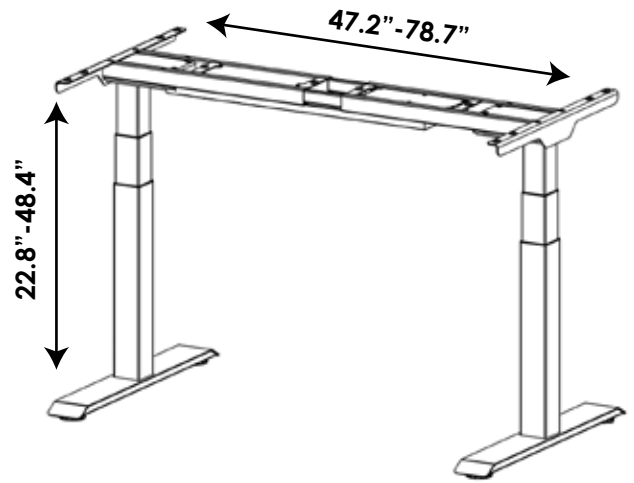

### Specifications

<b>Product Category:</b>	Electric Sit-Stand Desk
<b>Rank:</b>	Premium
<b>Material:</b>	Plastic,Steel
<b>Dimensions:</b>	22.8"~48.4"x47.2"x78.7"
<b>Frame Orientation:</b>	Rectangular
<b>Tabletop Thickness:</b>	≥0.98"
<b>Suggest Tabletop Size:</b>	(43.3"~86.6") x (27.6"~39.4")
<b>Weight Capacity:</b>	275lbs
<b>Width Range:</b>	47.2"~78.7"
<b>Height Range:</b>	22.8"~48.4"
<b>Column Design:</b>	Upright Column
<b>Column Segments:</b>	Three Stage Column
<b>Column Size:</b>	2.4" x 2.4", 2.5" x 2.5", 2.8" x 2.8"
<b>Leg Quantity:</b>	Two Legs
<b>Frame Color:</b>	Grey
<b>Adjustable Feet Pad:</b>	Yes
<b>Motor Quantity:</b>	2
<b>Power Input:</b>	100~240V
<b>Power Cord Length:</b>	3m (9.8ft)
<b>Max. Speed:</b>	38mm/s
<b>Controller Type:</b>	Button Control Panel
<b>Time Reminder:</b>	Yes
<b>Suggested Operating Temperature:</b>	-5°C~40°C
<b>IP Grade:</b>	IP20
<b>Certification:</b>	CE
<b>Accessory Kit Package:</b>	Normal/Ziplock Polybag



**Smooth Glide System**  
Improved design for tighter tolerance, quiet operation and eye-pleasing aesthetics

## Features



### Programmable Height Range

Customizes a minimum and maximum height setting that limits the operating range to accommodate objects around you, such as under desk cabinets.



### Easy-Assembly

Advanced frame design reduces set-up time while providing long-term stability.



### Proprietary Gyro-Current Collision Avoidance System

Improved sensing technology for better detection of soft and hard objects in the movement path.

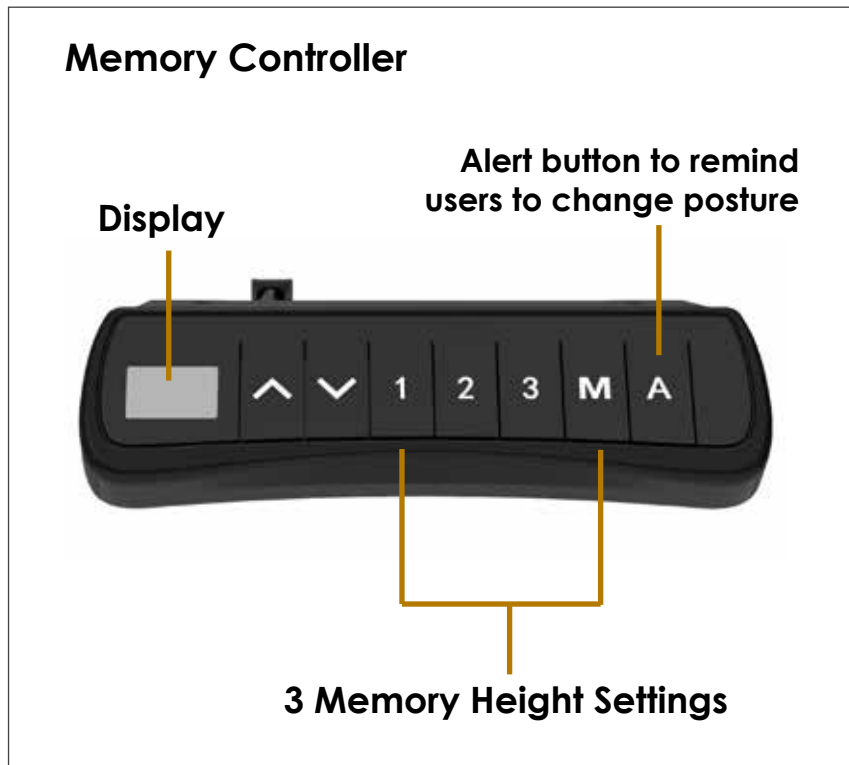

## Additional Features

- Motor(s) is(are) Thermal and Overload Protected: for safety and longevity
- 3 Programmable Memory: presets save your desired height
- Programmable height range: customizes the minimum and maximum height settings to accommodate objects around you, such as under desk cabinets or storage units
- Easy-Assembly: advanced frame design reduces set-up time while providing long-term stability for confident daily use
- Digital LED Memory Controller: for customizable settings
- Sit/Stand Time Reminder: for regular movement
- Programmable Proprietary Gyro-Current Collision Avoidance System: improved sensing technology for better detection of soft and hard objects in the movement path
- Three Stage Standard Column: offers more adjustability



## Slat Wall Bundle Options:

### Option A:

Wall Mount Accessory Rail Bundle  
 SKU: **WALL-MOUNT-AR**  
 1x- Wall Mount  
 1x- Slat Wall  
 1x- Paper Tray  
 1x- Pencil Cup  
 1x- Single Monitor Arm

### Option B:

Desk Mount Accessory Rail Single Sided  
 SKU: **DESK-MOUNT-AR-SINGLE**  
 1x- Desk Mount  
 1x- Slat Wall  
 1x- Paper Tray  
 1x- Pencil Cup  
 1x- Single Monitor Arm

### Option C:

Desk Mount Accessory Rail  
 Double Sided  
 SKU: **DESK-MOUNT-AR-DOUBLE**  
 1x- Desk Mount  
 1x- Slat Wall  
 2x- Paper Tray  
 2x- Pencil Cup  
 2x- Single Monitor Arm

\*Details of items are below

## Single Screen Aluminum Monitor Arm For Slat Wall

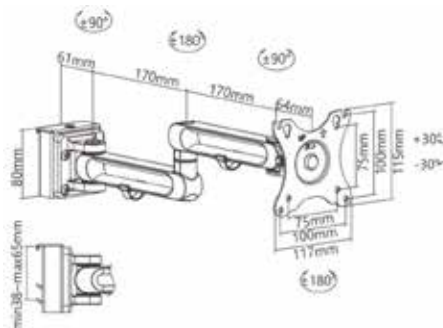

### Features

- Easy to adjust, no tools required
- Free-Tilting Design: for multiple monitor viewing angles
- Keyhole Pattern: allows for easy installation
- Space-Saving Design: free up and gain additional desktop work space
- Cable Clip: routes cables to reduce clutter for a clean look and more organized place

### Specifications

<b>VESA Compatible:</b>	75x75,100x100	<b>Product Category:</b>	Monitor Hanger
<b>Tilt Range:</b>	+30°~-30°	<b>Rank:</b>	Premium
<b>Swivel Range:</b>	+90°~-90°	<b>Material:</b>	Steel,Aluminum
<b>Screen Rotation:</b>	+180°~-180°	<b>Surface Finish:</b>	Powder Coating
<b>Arm Full Extension:</b>	13.4"	<b>Color:</b>	Matte White
<b>Installation:</b>	Hanger	<b>Dimensions:</b>	4.6"x18.3"x6"
<b>Quick Release VESA Plate:</b>	No	<b>Fit Screen Size:</b>	17"-32"
<b>Cable Management:</b>	Yes	<b>Screen Quantity:</b>	1
<b>Accessory Kit Package:</b>	Compartment Polybag, Normal/Ziplock Polybag	<b>Weight Capacity (per screen):</b>	17.6lbs



### Aluminum Slatwall Panel

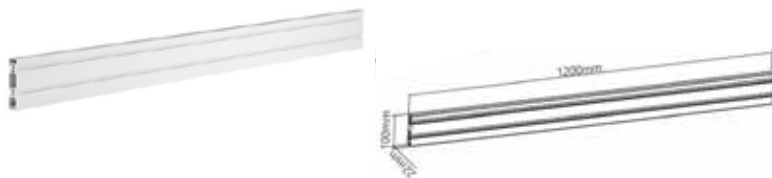

#### Features

- Two-Sided Slots: provide an economical and efficient approach to satisfy multiuser requirements
- Aluminum Construction: provides a sleek, lighter, and elegant look
- Modular System: changes the configuration or adds to your design at any time

#### Specifications

<b>Product Category:</b>	Slatwall System	<b>Color:</b>	Matte White
<b>Rank:</b>	Standard	<b>Dimensions:</b>	47.2"x0.87"x3.9"
<b>Material:</b>	Aluminum	<b>Weight Capacity:</b>	88lbs
<b>Surface Finish:</b>	Powder Coating	<b>Accessory Kit Package:</b>	No

### Slatwall Desk Mounting Pole

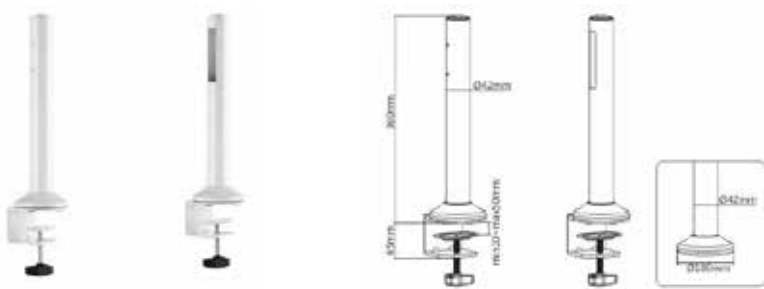

#### Features

- Two Mounting Options: both desk clamp and grommet are included
- Heavy-Duty Steel Construction: provides extra strength and durability
- Modular System: changes the configuration or adds to your design at any time

#### Specifications

<b>Product Category:</b>	Slatwall System	<b>Color:</b>	Matte White
<b>Rank:</b>	Standard	<b>Dimensions:</b>	3.9"x4.1"x16.7"
<b>Material:</b>	Steel	<b>Weight Capacity:</b>	110lbs
<b>Surface Finish:</b>	Powder Coating	<b>Accessory Kit Package:</b>	Normal/Ziplock Polybag

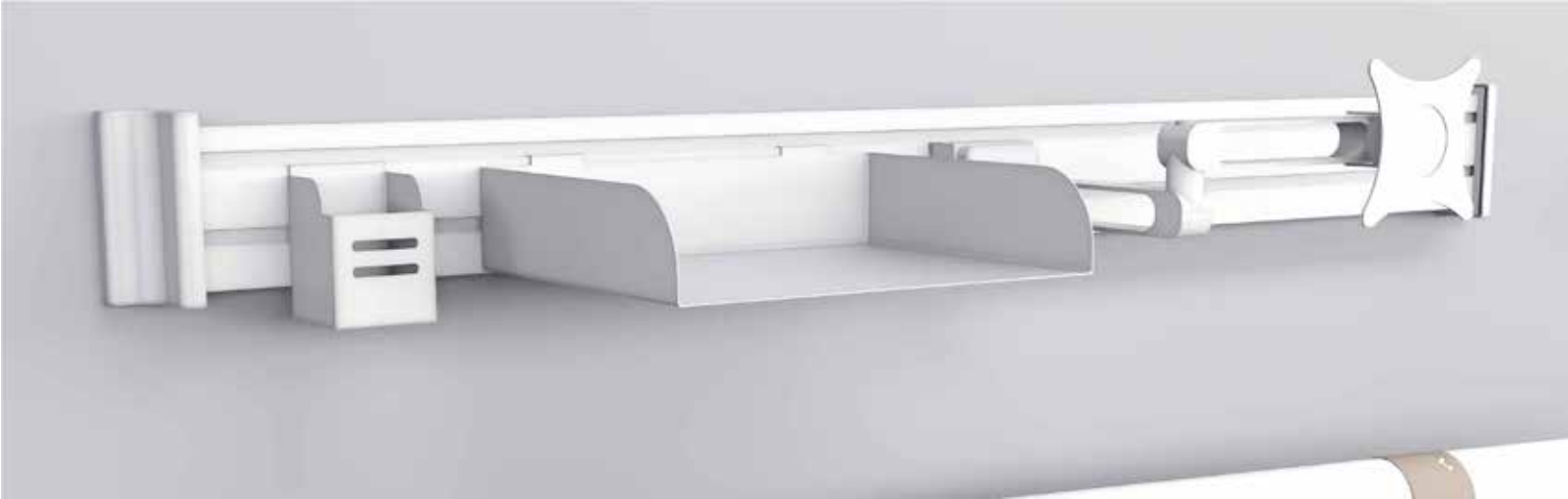

### Slatwall Wall Mounting Plate



#### Features

- Modular System: changes the configuration or adds to your design at any time
- Wall Mounting: optimizes desktop space while creating additional storage areas on wall

#### Specifications

<b>Product Category:</b>	Slatwall System
<b>Rank:</b>	Standard
<b>Material:</b>	Steel,Plastic
<b>Surface Finish:</b>	Powder Coating

<b>Color:</b>	Matte White
<b>Dimensions:</b>	1.8"x2.2"x4.7"
<b>Weight Capacity:</b>	110lbs
<b>Accessory Kit Package:</b>	Normal/Ziplock Polybag, Compartment Polybag

### Pencil Cup

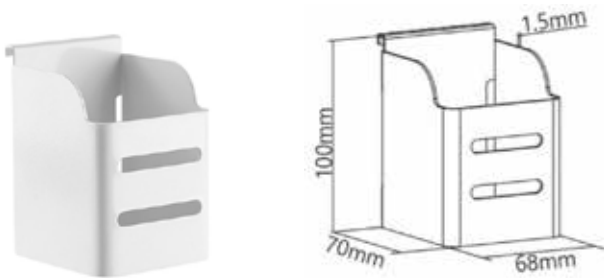

#### Features

- Make additional storage for less desktop clutter
- Heavy-Duty Steel Construction: provides extra strength and durability
- Modular System: changes the configuration or adds to your design at any time

#### Specifications

<b>Product Category:</b>	Slatwall System
<b>Rank:</b>	Standard
<b>Material:</b>	Steel
<b>Surface Finish:</b>	Powder Coating

<b>Color:</b>	Matte White
<b>Dimensions:</b>	2.7"x2.8"x3.9"
<b>Weight Capacity:</b>	2.2lbs
<b>Accessory Kit Package:</b>	No

## Paper Tray

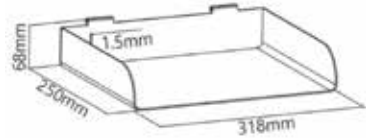

### Features

- Make additional storage for less desktop clutter.
- Heavy-Duty Steel Construction: provides extra strength and durability.
- Modular System: changes the configuration or adds to your design at any time.

### Specifications

<b>Product Category:</b>	Slatwall System
<b>Rank:</b>	Standard
<b>Material:</b>	Steel
<b>Surface Finish:</b>	Powder Coating

<b>Color:</b>	Matte White
<b>Dimensions:</b>	12.5"x9.8"x2.7"
<b>Weight Capacity:</b>	6.6lbs
<b>Accessory Kit Package:</b>	No

## Add-on

### Clamp-on Power Strip Holder



### Features

- Heavy-Duty Clamp Base: suits most desks with adjustable height
- Silicone Pad: prevents the device from scratching and accidental dropping (securely hold the device in place)
- Cable Management: elegantly hides any cables that are attached to displays

### Specifications

<b>Product Category:</b>	Power Strip Holder
<b>Rank:</b>	Standard
<b>Material:</b>	ABS,Steel,Silica Gel
<b>Surface Finish:</b>	Powder Coating
<b>Dimensions:</b>	3.9"x2.4"x6.1"
<b>Weight Capacity:</b>	0.66lbs
<b>Suggested Power Strip Width:</b>	1.6"~2.4"

<b>Clamp Range:</b>	0.39"~2"
<b>Installation:</b>	Clamp
<b>Cable Management:</b>	Yes
<b>Color:</b>	White
<b>Patent:</b>	2017206247219
<b>Accessory Kit Package:</b>	No





## Proper Screen Height

Sitting/Standing



## Laminate options for the workspaces.

### Domestic Laminate Options

\*USA Made



White Cypress

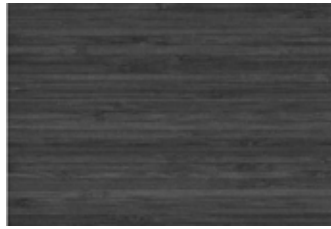

Asian Night

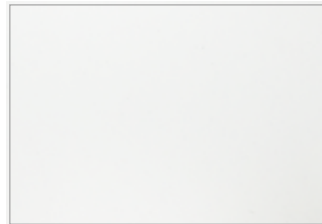

White



Black Cypress



Light Gray



Lakeland Salt



Blonde Surfside Ash



Natural Eucalyptus

### Import Laminate Options



Black Oak



Driftwood



Maple



Sea Salt